



Accelerated Location Detection with GPS & Galileo receivers

 **kannad marine**  
SEAS OF SOLUTIONS BRAND



# SAFEPRO+ AIS

## EPIRB

Combining the global 406 MHz professional search and rescue alert, with the localised locating and tracking power of AIS.

The SAFEPRO+ AIS EPIRB is MEOSAR Compatible® for enhanced detection and location performance and now with Infra-Red (Night-Vision) optical signal to aid detection of survivors in low light conditions. Infrared can be detected at greater range and in poorer conditions than standard EPIRB lights, therefore further accelerating recovery times.

# SAFEPRO+ AIS EPIRB

The world's most powerful EPIRBs, driving accelerated rescue times via:

- Faster alert detection on the 406 MHz frequency through our MEOSAR compatibility
- 4TECH® EPIRB, with four search and rescue frequencies, the SmartFind G8 AIS supports the Alert, Locate, Tracking and Recovery elements of search and rescue
- Greater location detection speed and accuracy, as the multi-constellation GNSS receivers work with a wider range of satellites including Galileo and GPS.
- Further enhancing our earlier World's first convergence of 406 and AIS, combining the global alerting of 406 MHz with the localised locating and tracking power of AIS

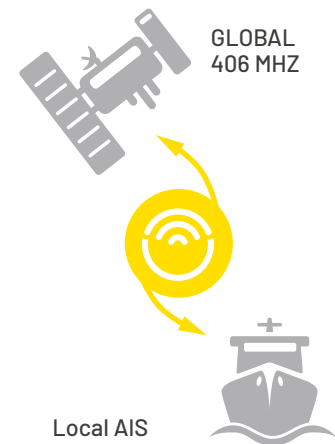

Kannad Marine SAFEPRO EPIRBs include innovation as standard; with ruggedized base, easy service battery, MEOSAR compatibility, compliance with the United States emergency hands free transport and the new GNSS requirement which raises the minimum requirements for new EPIRBs being sold globally. The additional false activation protection and multiple self-tests also offer total user confidence. Coupled with an unparalleled marine heritage, commitment to quality and a history of innovation, customers know they can trust McMurdo when their lives are at risk.

The SAFEPRO+ AIS is the first EPIRB to have standard 406 MHz, 121.5 MHz & GNSS capabilities AND include AIS for localised rescue. This combination is a result of new technology but also new attitudes to AIS as a search and rescue tool, plus the realisation that accelerated alert detection and location accuracy will save even more lives. This technology partnership will also help reduce demands on the Search & Rescue authorities as it should help vessel owners detect and resolve accidental activations through visibility of AIS signals.

## SAFEPRO Auto-Housing

A fully protective, spring loaded enclosure, the auto-housing automatically deploys and activates the EPIRB when it is submerged between 1 - 4m. The SAFEPRO auto-housing incorporates fixing points which ensure previous Kannad Marine auto-housing units can be retrofitted with minimum impact, when upgrading your vessels EPIRB.

SAFEPRO EPIRBs are available as either a category 1 or category 2 EPIRBs:

### Category 1 EPIRB models

Supplied inside an auto-housing and automatically deployed and activated when in contact with water (although they can also be manually activated).

### Category 2 EPIRB models

Supplied with a unique SmartTransfer bracket to prevent accidental activation, once manually removed from the bracket the EPIRB is activated manually or via water contact.



# SAFEPRO+ AIS EPIRB Features

Feature	Description
Optimised for MEOSAR	Enhanced detection capability for accelerated rescue
VHF homer	121.5MHz swept tone
406 frequency	International rescue frequency
GNSS receiver	GPS(L1) + GALILEO(E1), 72 channel, ceramic patch antenna
AIS capability	AIS for localized rescue
SmartTransfer	Manual bracket option, allowing transport without activating water switch
Auto-housing option	Automatic deployment when submerged 1-4 m
Activation method	Manual or water activation
SmartCarry	Concealed hands-free easy carry strap
SmartBase	Impact protection
SmartLight	3 lights, 360 degree coverage
Night vision	3 I/R LEDs
SmartSwitch	Reusable ON power button cover, to prevent accidental activation
Battery storage life	10 years from date of manufacture. (Lithium Iron Disulphide) (see Note 3)
SmartChange	Easy service battery
Global service network	200+ service centres across 80+ countries
Multiple self tests	120 short tests for system check and 20 Long tests which include testing of the GNSS receivers (see Note 1)
Warranty	1 + 4 years (see Note 2)

**NOTE 1** Recommendation – 1 test a month over a period of 10 years. Long tests twice a year over a 10 year period. Long tests to be conducted in full view of sky. Obstacles will increase time taken for GPS lock, reducing the battery life. Long Tests can also only be performed if GNSS receiver workability seems suspect.

**NOTE 2** Warranty is 1 year from date of purchase, an additional 4 years upon registration with Seas Of Solutions.

**NOTE 3** As a responsible manufacturer, Seas Of Solutions recommends a 5 year health check. Shore-based maintenance mandated vessels, battery health check or replacements should be carried out in accordance with flag Administration requirements and not exceeding 5 years.

## Understanding the MEOSAR Ecosystem

MEOSAR Improvements: Better Accuracy, Timeliness and Reliability. Cospas Sarsat has rolled out a new search and rescue infrastructure known as MEOSAR. The aim is: Determine beacon location within 5km, 95% of the time, within 10 minutes.

- The full MEOSAR constellation will comprise more than 70 satellites
- Near instantaneous beacon signal detection using bent pipe technology – average 46 minutes faster compared to LEOSAR
- Reduced response times with multiple signal bursts to improve speed and accuracy of location calculation
- Close to 100% reliability due to multiple antenna systems and MEOLUT networking
- Lives have already been saved with the early operational MEOSAR through faster alerts and greater accuracy, for example in Australia.

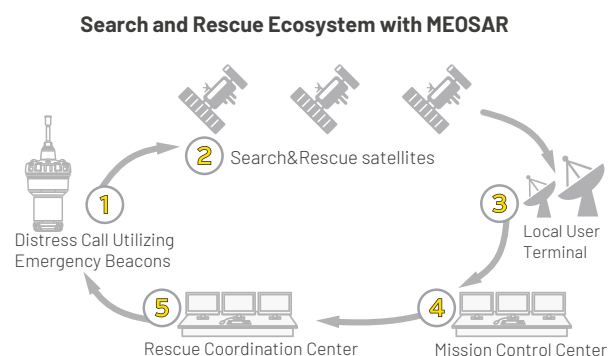

#### 406 MHZ TRANSMITTER

Frequency	406.040 MHz + 1kHz
Power output	5 W nominal
Modulation	Phase (16KOG1D)

#### 121.5 MHZ TRANSMITTER

Frequency	121.5 MHz
Power output	70 mW nominal
Modulation	Swept tone AM (3K20A3X)

#### AIS TRANSMITTER

Frequencies	161.975 MHz (AIS1); 162.025 MHz (AIS2)
Power output	1 W nominal
Modulation	Phase (16KOGXW)

#### GNSS RECEIVER

Constellations	GPS, Galileo
Frequencies	1575.42 MHz (GPS, Galileo)
Sensitivity	-167 dBm minimum
Satellites tracked	72 channel

#### STROBE LIGHT

Type	3 high intensity LEDs
Light output	0.75 cd minimum
Flash rate	23 flashes per minute
Night vision	3 Infrared LEDs

#### BATTERY

Type	Lithium iron disulphide
Operating life	48 hours minimum
Shelf life (in-service life)	10 years from date of manufacture typical in service (see Note 1)

#### ENVIRONMENT

Operating temperature	20 °C to +55 °C (-4° F to +131° F)
Storage temperature	-30 °C to +70 °C (-22° F to +158° F)
Automatic release depth	4 m maximum

#### DIMENSIONS (EPIRB)

Weight	710 g
Height/Width/Depth	423x104x103 mm (incl. antenna)
Length of antenna	206 mm

#### DIMENSIONS (MANUAL BRACKET)

Weight	110 g
Height/Width/Depth	270x125x121 mm

#### DIMENSIONS (FLOAT FREE ENCLOSURE)

Weight	1075 g
Height/Width/Depth	416x126x132 mm

#### STANDARDS APPLIED (SEE NOTE 2)

COSPAS-SARSAT	C/S T.001 C/S T.007
Europe	MED (wheelmark)
USA	USCG & FCC; FCC ID; TBA; 4 7 CFR Parts 80, 2;
UK	Ensign Mark
ITU-R	RecM.1371

International standards	IEC 61097-ED4; IEC 60945 incl. Corrigendum1; Industry Canada RSS-287; AS/NZS 4280.1; IMO MSC/Circ. 862
IMO regulations	A.662(16); A.694(17); A.814(19); MSC.471(101)

#### PART NUMBERS

SAFEPRO+ AIS Manual EPIRB	23-002-011A
SAFEPRO+ AIS Auto EPIRB	23-002-511A

**NOTE 1:** As a responsible manufacturer, McMurdo recommends a 5-year health check at the nearest McMurdo approved service agent. Shore-based maintenance mandated vessels, battery health check or replacements should be carried out in accordance with flag Administration requirements and not exceeding 5 years.

**NOTE 2:** Approvals for the various standards is pending

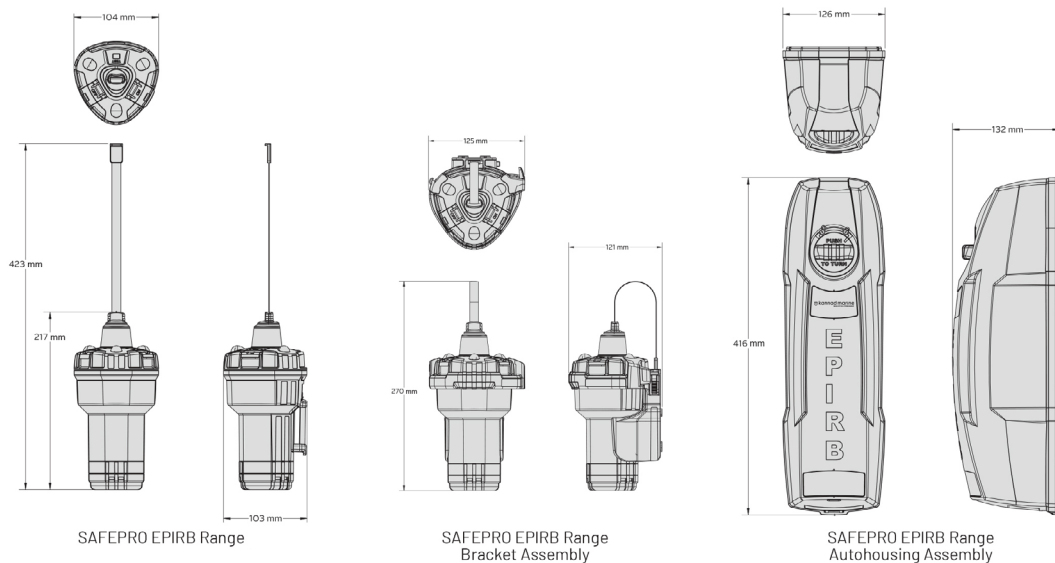

## Safe Operational EPIRB Life

Seas of Solutions Safe Operational EPIRB Life guidance is that EPIRBs should be considered for decommissioning after 12-15 years, as this reduces the risk of environmental impact on beacon performance and ensures end users have beacons with the latest technology. As a result, the SAFEPRO+ AIS EPIRB range is supplied with a ten-year battery, but battery replacement kits have a minimum five-year battery, to encourage regular professional checks of the units and reduce the likelihood of the beacons remaining on board vessels beyond the recommended operational life.