

COBHAM

SAILOR H1252A/TT-3608A-220 Printer SAILOR H1252B/TT-3608A Printer

Technical manual



SAILOR H1252A/TT-3608A - 220 Printer
SAILOR H1252B/TT-3608A Printer

User manual

Document number: 98-124013-B
Release Date: 20 December 2013

Disclaimer

Any responsibility or liability for loss or damage in connection with the use of this product and the accompanying documentation is disclaimed by Thrane & Thrane. The information in this manual is provided for information purposes only, is subject to change without notice and may contain errors or inaccuracies. Manuals issued by Thrane & Thrane are periodically revised and updated. Anyone relying on this information should acquire the most current version e.g. from cobham.com/satcom or from the distributor. Thrane & Thrane is not responsible for the content or accuracy of any translations or reproductions, in whole or in part, of this manual from any other source.

Thrane & Thrane A/S trading as Cobham SATCOM.

Copyright

© 2013 Thrane & Thrane A/S. All rights reserved.

Record of revisions

Rev	Description	Release Date	Initials
B	Cobham rebranding	December 2013	CMA

Contents

PART I H1252A / TT-3608A-220 H1252B / TT-3608A

1	General information	2
2	Installation	3
2.1	Mounting possibilities	3

PART IIH1252B / TT-3608A

1	General information	6
1.1	Introduction	6
1.2	Principle of operation	6
1.3	Technical data	6
2	Maintenance/modification	7
2.1	Disassembling to remove the mains transformer	7
2.2	Disassembling and mounting of the ON-OFF switch	8
2.3	Mounting the DC power supply and reassembling	8
2.3.1	Mounting of the DC power supply	9
2.3.2	Modification of the printer main control board	9
2.3.3	Reassembling of the printer	10
2.4	Electrical connections	11
3	Service	12
3.1	Printer selftest	12
3.2	Module check of the DC power supply	12
3.3	Check after repair	12
4	Mechanical disassembling of printer	13
5	Circuit description	14
5.1	DC power supply	14

1 General information

H1252A/TT-3608A-220 Hardcopy printer is an OKI MICROLINE 182/280 printer for 220/240V AC operation.

H1252B/TT-3608A Hardcopy printer is an OKI MICROLINE 182/280 printer with built-in DC power supply for 10.5-32V DC operation.

The printer is as standard delivered with a Roll Paper Stand, other paper types can also be used, please refer to the OKI manual for detailed information.

The printer is as standard delivered with the mounting kit H1250, it can also be mounted on the H2192 GMDSS Console using the mounting plate which is delivered together with the H2192 GMDSS Console.

Paper roll, Power cable and Centronics cable are supplied with the Printer.

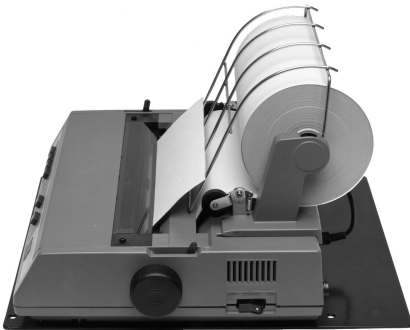

501279



501274



501278

2 Installation

2.1 Mounting possibilities

Mounting kit H1250

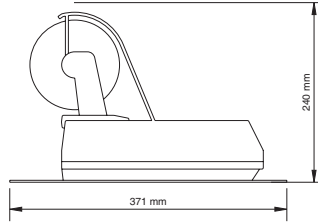
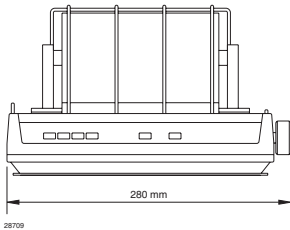

Drilling plan

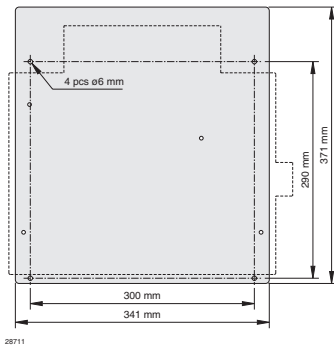

Mounting kit H2192

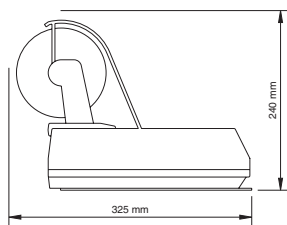
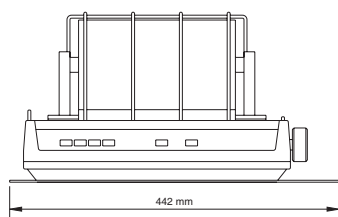

Drilling plan

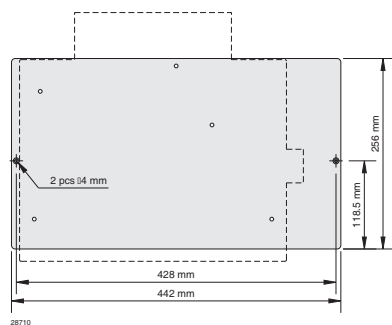

Printer with mounting kit H1250

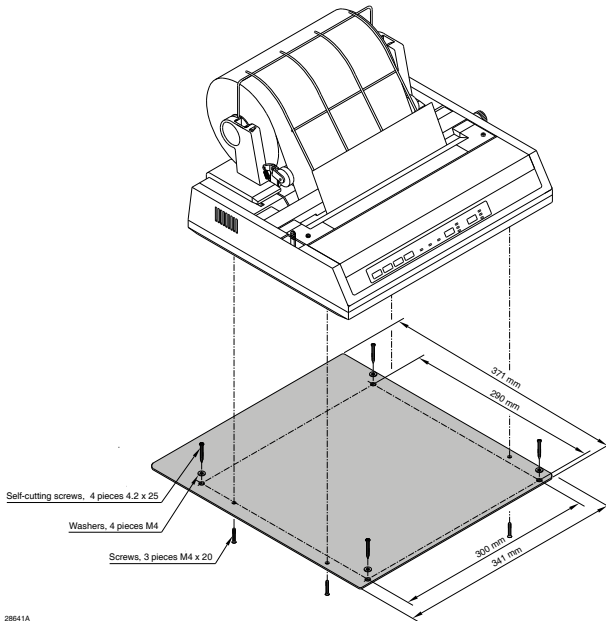

Printer with mounting kit H2192

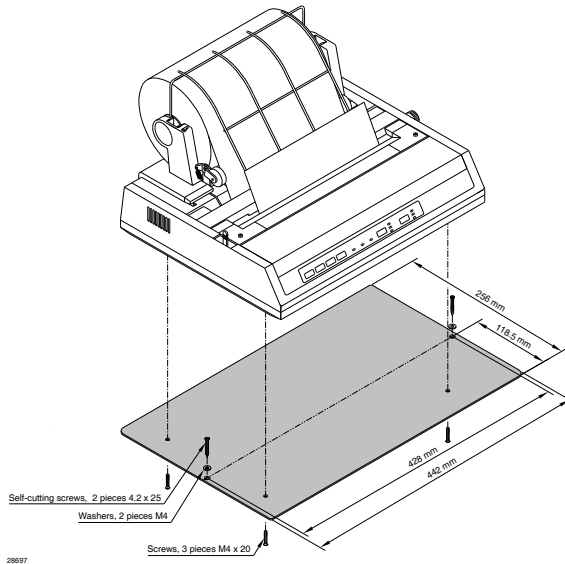

1 General information

1.1 Introduction

This section gives you all the necessary informations to maintain the DC power supply module. It also specifies how to modify the printer to operate on DC supply instead of AC supply.

1.2 Principle of operation

The power supply module is constructed to operate from a battery voltage of 10.5V DC to 32V DC to deliver the necessary voltages for the printer. The voltage conversion takes place in a “flyback” switch converter, which is controlled by a current mode controller. The regulation of the output voltage is controlled via a separate winding of the transformer, which also delivers the power for the control circuit. At the input and at the output are placed filters to suppress the switch noise.

Blockdiagram

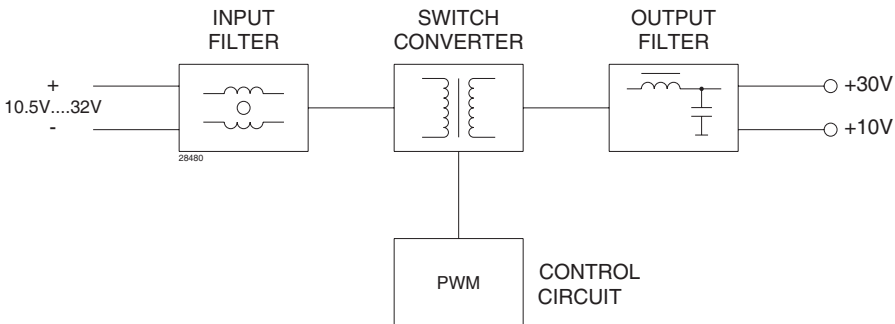

1.3 Technical data

Input voltage range	: 10.5V DC to 32V DC
Current consumption	: max. 4.5A (fuse = 6.3AT)
Output voltages	: 10V DC / 0.3A
	: 30V DC / 0.8A
Noise from input terminals	: better than CEPT Rec. T/R 34-01
On/off	: by switch
Operating temperature	: -15° C to +55° C

2 Maintenance/modification

This section is intended for use when modifying the printer to operate from DC supply instead of 220V AC supply.

2.1 Disassembling to remove the mains transformer

Remove the access cover by lifting up rear edge.

Pull out the platen knob.

Remove the two screws.

Remove the top cover by lifting up the front and pushing it backward.

Remove the transformer output cable from the printer Main Control Board.

Remove the ground strap screw, but keep it for later use.

Remove the two screws, that fix the transformer, but keep them for later use.

Remove the transformer assembly with power PCB and AC cord receptable by lifting upwards.

Remove the 220V~ label located at the panel cut out for the AC cord receptable.

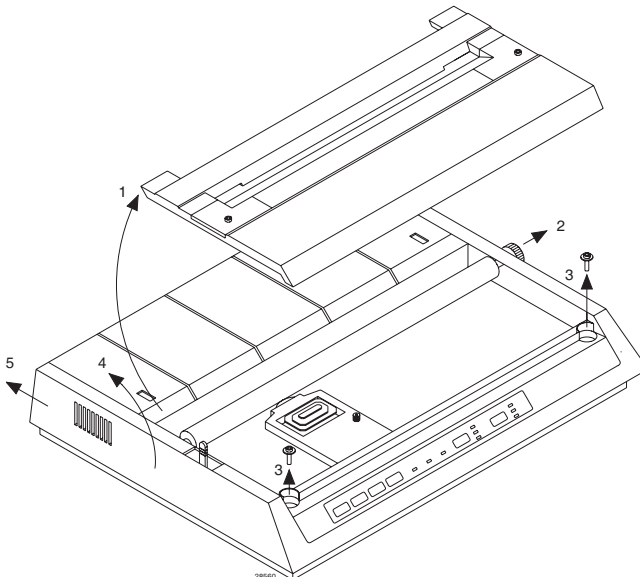

2.2 Disassembling and mounting of the ON-OFF switch

It is necessary to remove the ON-OFF switch from the transformer assembly to use it again on the DC power supply module.

Remove the filter and switch board from the transformer by pulling it off.

Unsolder the ON-OFF Switch.

Solder the switch to the two loose wires on the DC power supply module. Then twist the wires to the switch to suppress noise.

2.3 Mounting the DC power supply and reassembling

Remove the cover on the glue pad and when the power supply module is placed properly, the switch is placed in the slots in the cabinet and is pressed down to the glue pad.

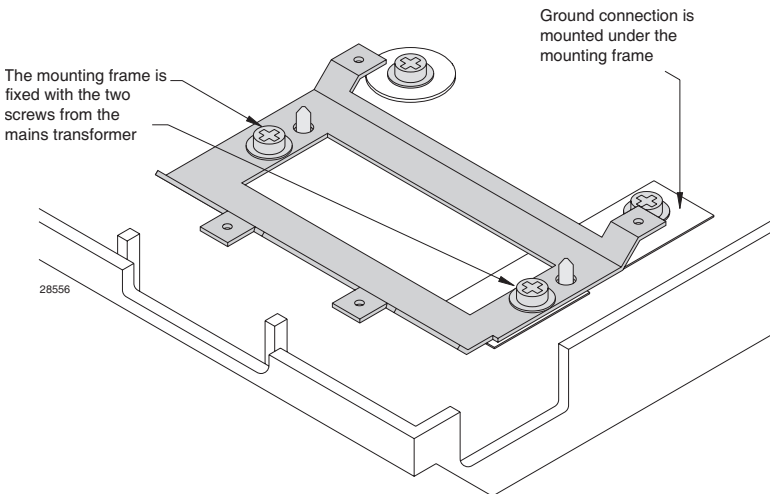

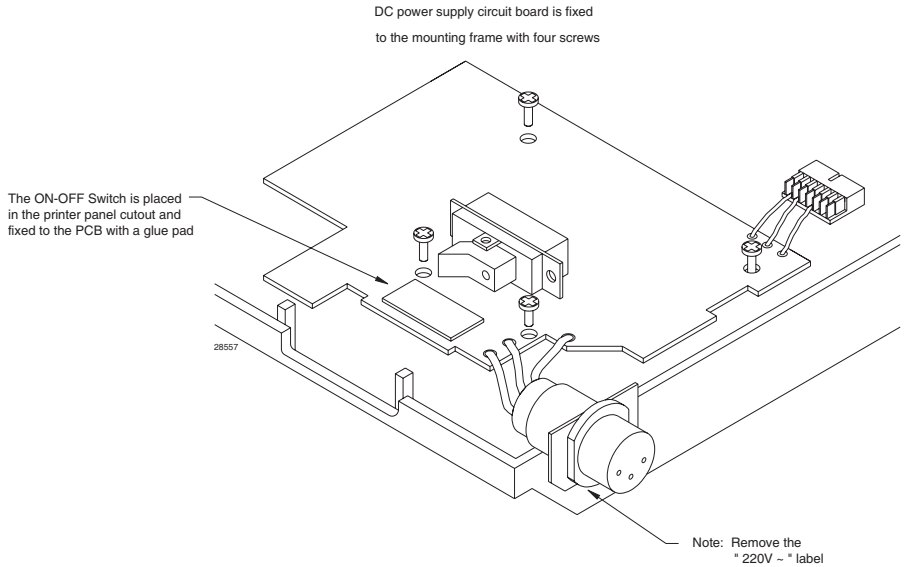

2.3.1 Mounting of the DC power supply

Place the ground connection over the rear transformer hole, and fix it with the ground screw.

Place the mounting frame where the transformer was mounted, and fix it with the two screws from the transformer.

Then place the DC power supply module on the mounting frame, and fix it with four screws.

Be sure the power ON-OFF switch is correctly placed in the panel cut out slot.

Press the plate with the DC input connector in to the panel cut out the former AC cord receptable.

Connect the output cable to the printer Main Control Board.

2.3.2 Modification of the printer main control board

If the printer is equipt with a DC power supply module of other type than from ECI, it is necessary to modify the printer main board. As seen below, the diode D28 (D10) on the printer main board is short circuited.

If the printer is equipt with a DC power supply module from ECI, module no. 628471 it is **not** recommended to short circuit the diode D28 (D10) on the printer main board.

Run the printer selftest programme.

Switch on the ON-OFF switch and simultaneously press down the “line feed” button. After a few seconds (at low input voltage) the printer starts the selftest printing routine, which means that the DC power supply is OK.

Switch off the printer.

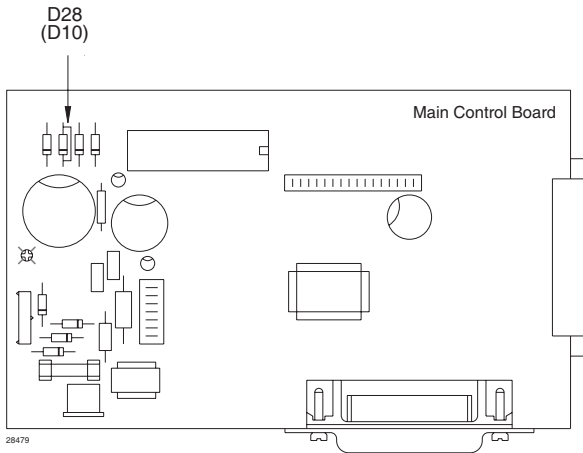

2.3.3 Reassembling of the printer

Place the top cover by lifting the front end and place holes in the rear end into the two small hooks in the bottom cabinet.

To reassemble the printer, do the reverse procedure of the disassembling.

Then run the selftest programme of the printer. (See above)

2.4 Electrical connections

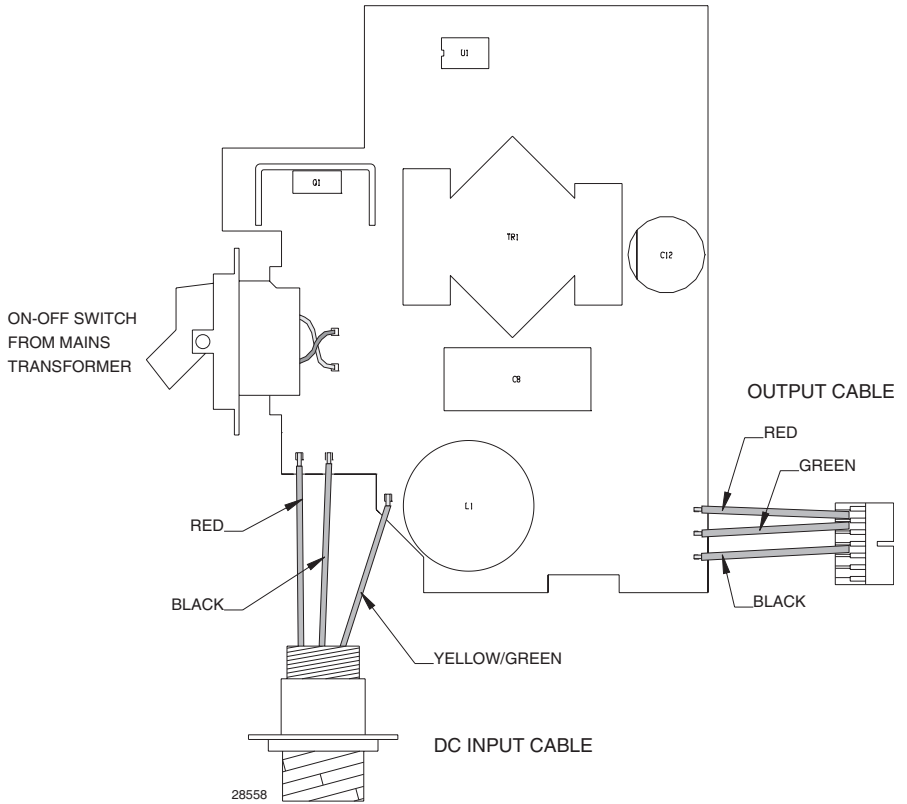

3 Service

3.1 Printer selftest

To do a performance test of the DC power supply, a selftest programme in the printer can be used.

Connect a DC power source of 10.5V to 32V to the DC input connector.

Switch on the ON-OFF switch and simultaneously press down the “line feed” button.

After a few seconds (at low input voltage) the printer starts the selftest a printing routine, which means that the power supply is OK.

Switch off the printer.

3.2 Module check of the DC power supply

Connect a dummy load of $33\Omega/30W$ to 30V output.

Connect a dummy load of $33\Omega/5W$ to 10V output.

Connect a DC power source of 10.5V to the DC input connector.

Switch on the power supply module. The module has to start up within 4 seconds.

Connect a voltmeter to the 30V output and read $28 \pm 2V$.

Connect a voltmeter to the 10V output and read $9V \pm 1V$.

Connect a DC power source of 32V to the DC input connector.

Switch on the power supply module. The module has to start up within 1 second.

Connect a voltmeter to the 30V output and read $33V \pm 2V$.

Connect a voltmeter to the 10V output and read $10V \pm 1V$.

Disconnect the dummy load from the 30V output and read the voltage to $39V \pm 2V$.

3.3 Check after repair

If any repair has occurred to the power supply module, then perform chapter 3.2 MODULE CHECK OF THE DC POWER SUPPLY.

4 Mechanical disassembling of printer

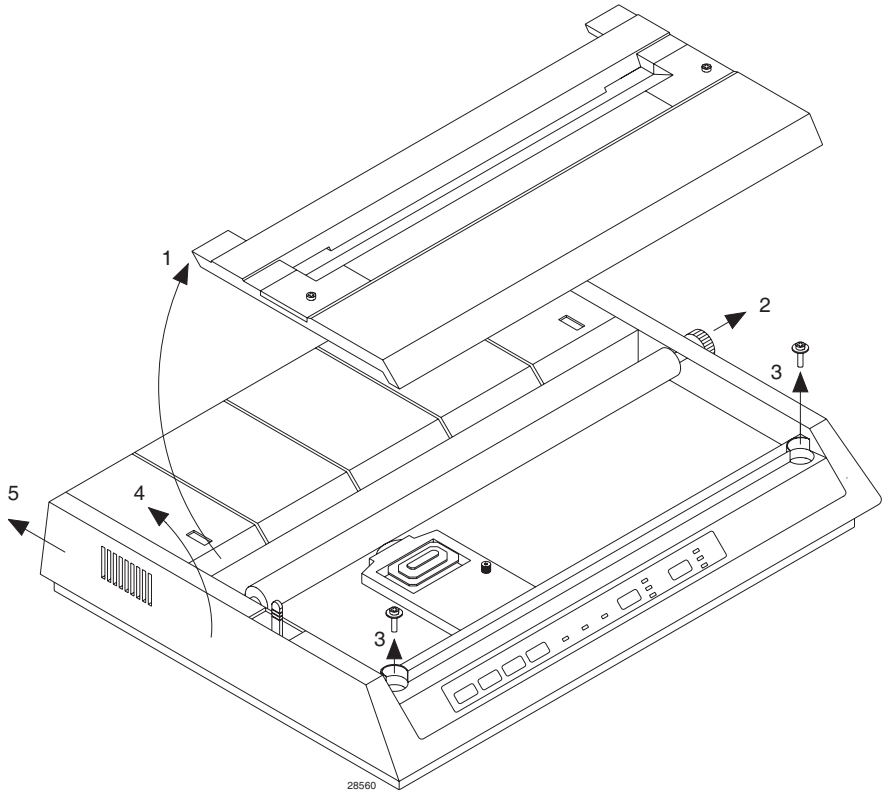

5 Circuit description

5.1 DC power supply

To suppress noise on the supply wires a filter is build around the current compensated choke L1. Furthermore the RC snubbers across the transformer prevent unwanted oscillations during transition time. The diode D7 in conjunction with R16 and C19 clamps the transient voltage spikes across the switch transistor Q1.

When the supply is switched on, the capacitor C6 is charged by means of R1 and when the voltage exceeds approx. 8.7V the controller U1 turns on. After a few cycles power is delivered from the bootstrap winding of the transformer to maintain the supply to the controller U1. When switching of the supply voltage, the power from the transformer disappears. This means the supply voltage to U1 decreases to approx. 7.6V and the controller U1 switches off.

The rectified voltage from the bootstrap winding is also used to regulate the output voltages, which mainly is determined by R8 and R11. The feedback voltage is led to U1 pin 2. The resistors R10 and R9 and the capacitor C17 form the compensating circuit for the voltage regulation.

The controller is working at a fixed frequency of approx. 100 kHz, determined by R7 and C16.

The switch current is sensed by R15 and led to U1 pin 3 after being filtered by R14 and C18. The current sense voltage is a ramp voltage, which is compared to a DC level determined by the voltage regulation circuit. When the ramp exceeds the DC level, the controller U1 switch off the FET Q1. This current sense circuit forms a current regulation loop, which is stabilizing the over all regulation and prevents high current to damage the switch transistor Q1.

When Q1 is on, the output diodes D3 and D4 is reversed biased and current to the load is delivered from the capacitors C12 and C13. During the off time of Q1, the transformer outputs deliver the currents to the capacitors C12 and C13 and to the load.

The chokes L2 and L3 are parts of lowpass filters to suppress voltage spikes.

Because of the converter principle, which is a ringing choke flyback type, without direct feedback from the output the voltages, the output voltages are load dependent. At input voltage under approx. 15V and at full load, the converter "changes frequency" and gets an irregular duty-cycle. That is normal behaviour.

At low input voltage the start up time can be as long as 4 seconds, depending on the load.

Component location DC power supply

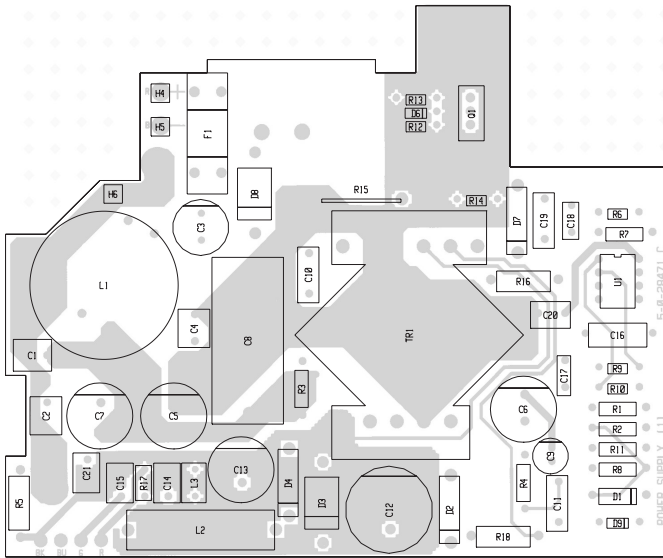

View from component side with upper side tracks.

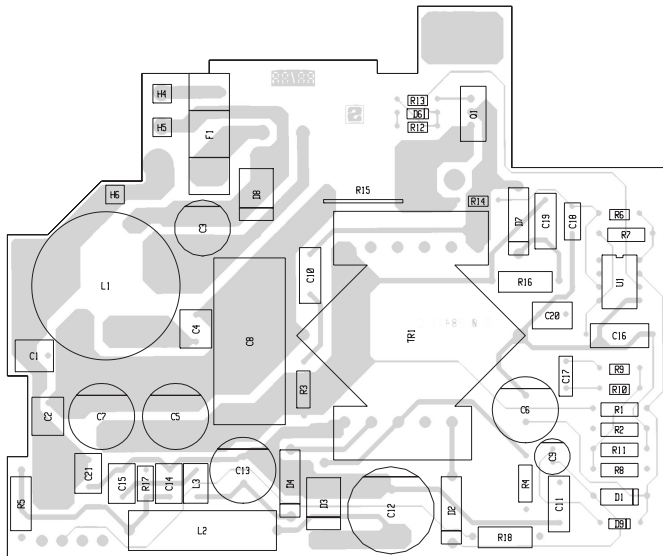

View from component side with lower side tracks.

PCB rev. 28471C

Schematic diagram DC power supply

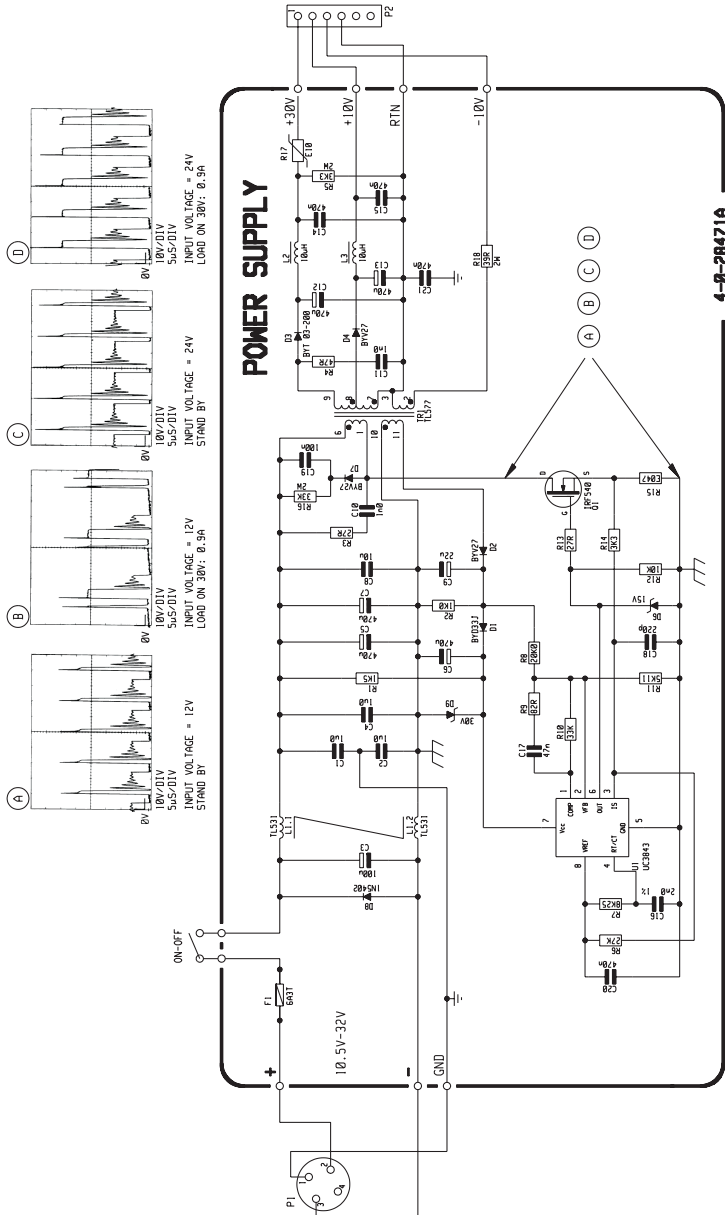

This diagram is valid for PCB rev.28471C

