

SAILOR® 4300 L-BAND

COBHAM

Securing your link to Iridium's next generation satellite services

Product Sheet

Compact and incredibly easy to install, the SAILOR 4300 Iridium Certus Connected™ terminal is the pinnacle of L-band satcom performance and reliability. It ensures that your link to the Iridium® NEXT network is always available so you can operate safer, smarter and more efficiently through the power of always available communication and digitally connected applications.

Next generation

Iridium CertusSM is a new portfolio of global satellite services powered by Iridium® NEXT, a ground-breaking L-band global satellite constellation, which features a cross-linked Low-Earth Orbit (LEO) architecture to provide 100% coverage over the earth's surface. With SAILOR 4300 providing your on board link, you are guaranteed high bandwidth IP connectivity and three high-quality voice lines for global calling wherever you are.

Heavyweight applications

Available in bulkhead and 19" rackmount configuration, SAILOR 4300 offers the most reliable connection to the Iridium® NEXT satellite network with speeds suitable for data-heavy applications including; videoconferencing, multi-user Internet/VPN, IoT and telemedicine, alongside regular usage including email, electronic forms/reporting and crew communication.

Operational continuity

SAILOR 4300 is designed to withstand the harshest maritime environments. Reliability is high and lifecycle costs are inherently low – it is built to such high quality that there is no scheduled service interval and no maintenance for at least 10 years after installation. But should something go wrong, you have the support and knowledge of Cobham

SATCOM's unique Global Service Network to get you back online wherever you are.

Understanding innovation

As the market leader in maritime L-band terminals, Cobham SATCOM delivers innovation based on our innate understanding of the operational realities and

strategic goals of our service provider partners and end-users. When moving to Iridium® NEXT using SAILOR 4300, you get the best available Iridium CertusSM voice and data service anywhere in the world from an easy to install terminal with a rich feature-set and class-leading lifecycle costs.



SAILOR® 4300 L-BAND

The flexible global connectivity and voice solution



SAILOR 4300 L-Band Above Deck Unit (8 kg)

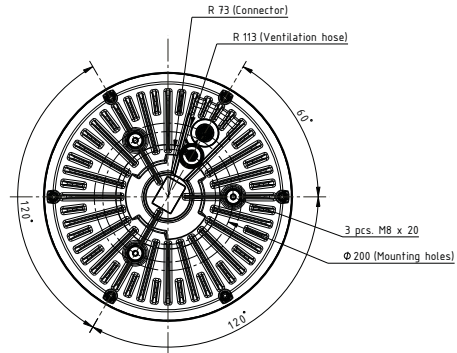
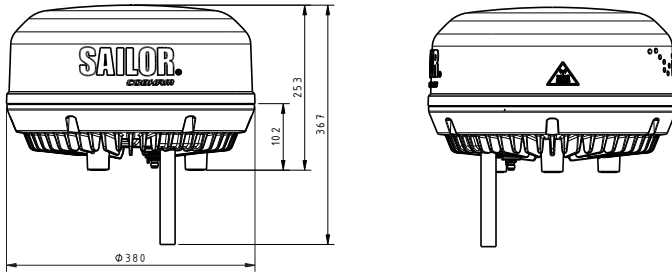

SAILOR 4300 L-Band Below Deck Unit (3.2kg)

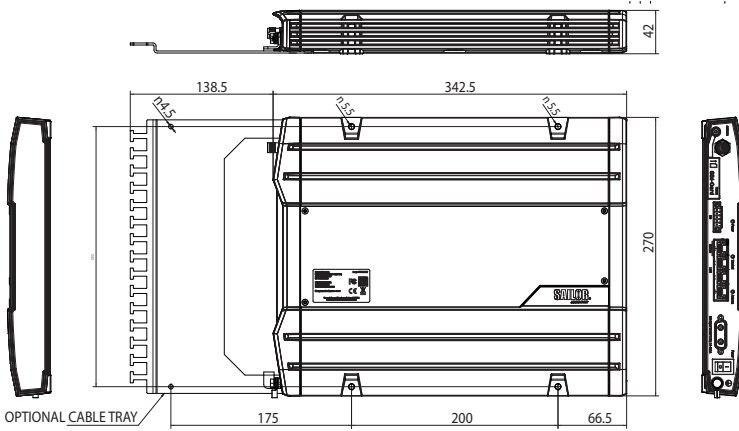

APPROVALS

Iridium next approved. Compliant to RED, CE Marked. Testet to FCC part 25

FREQUENCY BAND

Rx	1616 - 1626.5 MHz
Tx	1616 - 1626.5 MHz

RECOMMENDED ANTENNA CABLE

Cable loss	Maximum 1.8ohm DC loop resistance maximum 10dB loss at 80MHz
------------	---

ANTENNA CONNECTORS

ADU	TNC, female
BDU	TNC, female

POWER SUPPLY AND CONSUMPTION

DC input range (isolated)	10.8V to 31.2V
Power (max) incl. antenna & PoE output	120W @ 10-32 V

ENVIRONMENTAL CONDITIONS

Ambient Temperature	-25 to +55°C
Storage	-35 to +85°C
Automatic thermal surveillance	Shuts down system gradually in ease of own temperature
BDU operating humidity	95% non-condensing at +40°C
BDU enclosure	IP31
ADU operating humidity	95% non-condensing at +40°C
ADU enclosure	IPX6

VIBRATION (ADU)

Vibration, operational	Sine: Certified for IEC 60945 (8.7.2) Random spectrum 0,92 g rms x 3 axis 5 to 20 Hz: 0.01 g2/Hz 20 to 500 Hz: -3 dB/octave
Vibration, survival	Sine: Certified for IEC 60945 (8.7.2) dwell Random spectrum 1.7 g rms 2 h x 3 axes (6 h total): 5 to 20 Hz: 0.05 g2/Hz 20 to 150 Hz: -3 dB/octave

SHIP MOTION

Roll	+/- 30 deg. per. 8 s, max 0.5 g tan.
Pitch	+/- 10 deg. per. 6 s, max 0.5 g tan.
Yaw	+/- 8 deg. per. 50 s, max 0.2 g tan.
Surge	+/- 0.2 g
Sway	+/- 0.2 g
Heave	+/- 0.5 g
Turning rate	+/- 6 deg/s; acc. 1 deg./s ²
Headway speed	30 knots (15 m/s)
Wind	200 km/hr (108 knots)

MECHANICAL SHOCK

20g/11 half-sine

SPECIFICATION

Standard IP	176/704 kbps
Ethernet/LAN	4 ports
I/O Connector	1 connector
Status LED	Full status LED panel
SIM Card Slot	1 SIM Card slot for Iridium SIM card

For further information please contact:
satcom.ohc@cobham.com