

THE SAILOR® SP3500 ATEX PORTABLES

COBHAM

Tough Job. Tough Conditions. Tough Equipment.

Product Sheet

Communication is vital for the safety and efficiency on board all vessels operating in hazardous environments, such as tankers, supply vessels and other offshore operations. Choosing a portable radio specially designed for this harsh environment is a must. Fully waterproof, the ATEX versions of the SAILOR SP3500 portable series is built specifically for use at sea, so it can be trusted to provide reliable communication whatever the conditions.

All SAILOR SP3500 ATEX versions are designed with the user in mind, and are ideal for work in hazardous marine environments. The unique SAILOR SP3540 VHF is both ATEX and GMDSS approved, so it can be used for on board communication and to fulfill safety requirements if an incident should occur.

With large tactile buttons and control knobs combined with a user-friendly interface, operation of the SAILOR SP3500 ATEX portables could not be simpler, and when in the middle of a vital operation, be it a bunkering operation, hazardous cargo transfer or an oil spill clean-up, complicated operation of your radio is the last thing you need. Every SAILOR SP3500 portable radio also comes with a large, easy to read display with a red backlight to protect your night vision.

Years of experience with maritime design have resulted in the innovative, user-friendly design of the SAILOR SP3500 ATEX portables, which is backed up by incredible value and a high quality world-wide service network – On Board Service Center.

The ATEX Family

The SAILOR ATEX portable series is part of the SAILOR SP3500 family, which features seven models covering all maritime applications. There are three high-quality, durable ATEX models specifically designed for use in the dangerous offshore and tanker environment, whilst at the same time offering superb value.

- SAILOR SP3530 Portable VHF ATEX
- SAILOR SP3540 Portable VHF ATEX GMDSS
- SAILOR SP3560 Portable UHF ATEX

All feature powerful transceivers and high quality audio ensuring that all parties can be heard loud and clear even when working in windy and noisy conditions. The

SAILOR name gives you confidence that your portable VHF was built for the job at sea, with such features as:

- Robust design
- Waterproof (IP67)
- Large display
- Clear sound
- Large tactile buttons
- Ribbed grip
- Interface to external accessories – e.g. SAILOR 3595 Hand Microphone ATEX

The SAILOR SP3500 ATEX versions conform to the 94/9/EC ATEX Directive. The approved rating is II 2 G Ex ib IIC T4. Accessories has been approved together with the SAILOR SP3500 ATEX radios.



THE SAILOR® SP3500 ATEX PORTABLES



Tough Job. Tough Conditions. Tough Equipment

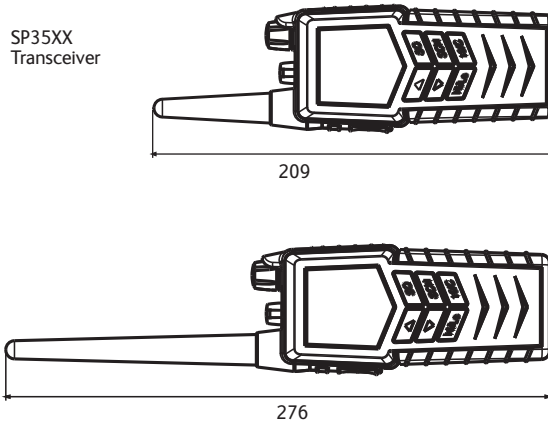
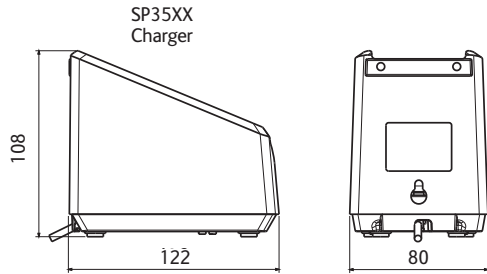

The complete package

The SAILOR SP3530/SP3540/SP3560 packages consist of:

- Transceiver and antenna
- Belt clip and lanyard
- Li-Ion rechargeable battery and charger*
- AC/DC converter/adaptor
- DC connection
- Operators manual
- The SAILOR SP3540 also includes a Lithium battery for GMDSS application.

Wide range of accessories

In addition to the standard package a range of accessories are available, making the SAILOR SP3500 portable series even more vital for all marine applications:

- SAILOR 3590 Hand Microphone with Interface for OTTO Engineering accessories
- SAILOR 3595 Hand Microphone ATEX* with interface for SAVOX and PELTOR accessories
- Interface cables for PELTOR and SAVOX accessories
- Service/programming cable
- Dual charger
- Leather carry and soft carry bags with shoulder strap

* SAILOR 3595 Hand Microphone ATEX is ATEX approved for SAILOR SP3530/SP3540/SP3560 ATEX Portables

	SAILOR SP3530 VHF ATEX	SAILOR SP3540 VHF GMDSS ATEX	SAILOR SP3560 UHF ATEX
Approvals	R&TTE FCC IC	MED (Wheelmark) FCC IC	R&TTE FCC IC

CHANNELS AND FREQUENCIES

Frequency range	149.3 - 174 MHz	149.3 - 174 MHz	440 - 470 MHz
Channel separation	25 and 12.5 kHz	25 kHz	25 and 12.5 kHz
Pre-programmed channels	Int., US, Canadian and BI	GMDSS	16 maritime
Additional programmable channels	100	100	100
ATIS call sign programmable	X	X	X

FEATURES

Squelch control	X	X	X
Transmitter power (Hi/Low) (radiated)	2/1W	2/1W	2/1W
Dual watch, Tri-watch, scanning	X	X	X
Call Channel Program and Selection	X	X	X
Red back light with dimming	X	X	X
Keypad lock	X	X	X
Keypad beep On/Off	X	X	X
Backlit keypad	X	X	X
Light on key press or manual only	X	X	X
Display contrast	X	X	X
CTCSS	X	X	X
Scrambler	X	X	X
Battery save function	X	X	X
Battery level indicator	X	X	X

BATTERY

1650mAh Rechargeable Li-Ion battery	X	X	X
GMDSS battery			X

For further information please contact:

satcom.maritime@cobham.com